

CHF711TOP



Electric combi oven with touch screen 7 trays

1/1 GN

Finally you can see first-hand all the advantages of a higher quality oven thanks to the CHF 711 TOP model with 7 1/1 GN trays.

You will discover a sturdy and sophisticated design that features exclusive technology to cook the most elaborate dishes evenly.

Without sacrificing the ease of use and versatility in the dishes.

All you need to make the difference in the kitchen is a MILLENNIAL oven with Airflowlogic, Humilologic and Drylogic patented systems.

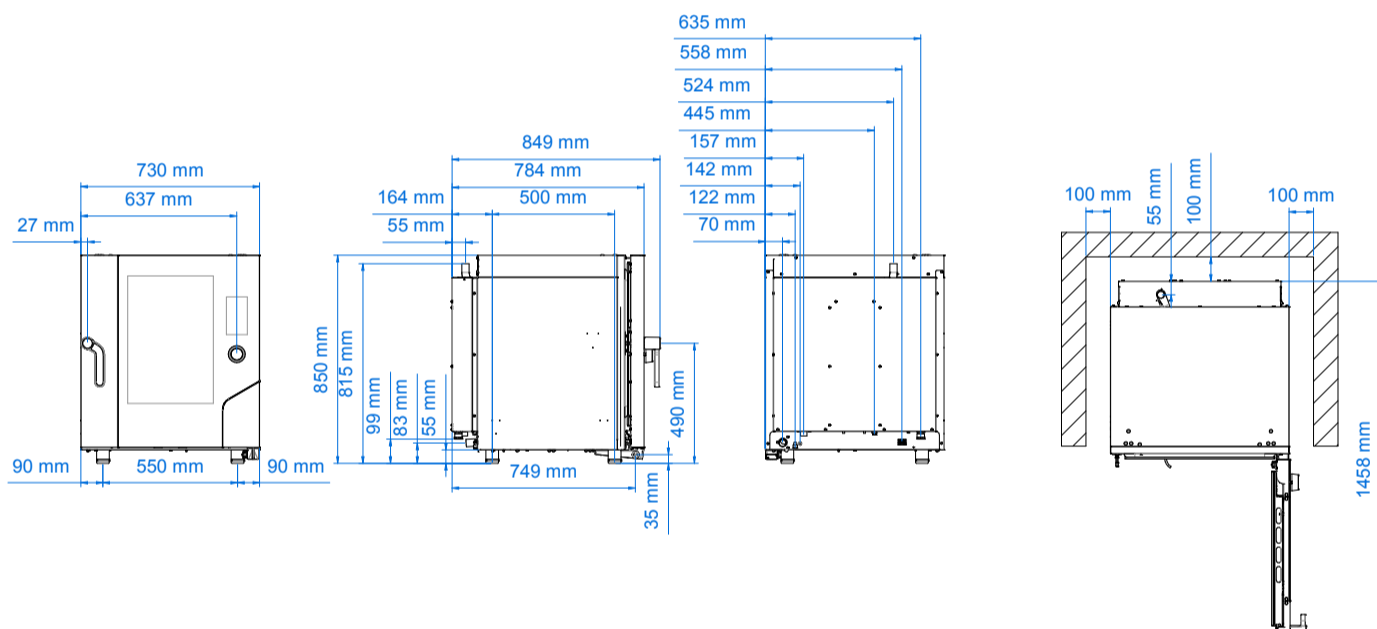

Dimensional features

Dimensions (WxDxH mm)	730 x 849 x 850
Weight (kg)	98
Distance between rack rails (mm)	68

Electrical features

Power supply (kW)	11,4
Frequency (Hz)	50/60
Voltage (V)	AC 380/400 3N
N° motors	2 bidirezionali
Boiler (kW)	/
Protection against water	IPX5

Functional features

Power	Electricity
Capacity	N° 7 trays/grids 1/1 GN
Type of cooking	Semistatic + ventilated
Steam	Direct steam controlled by touch screen (10 levels)
Cooking chamber	AISI 304 stainless steel
Temperature	30 - 270 °C
Temperature control	Digital probe thermometer
Control panel	Touch screen
N° programs	500
Programmable cooking steps	10
Pre-heating temperature	180 °C
Pre-heating function	Programmable
Door	Right side opening Ventilated Inspectionable glass
Modularity	Yes
Feet	Adjustable

Equipment

Cardboard box dimensions with pallet (WxDxH mm)	790 x 905 x 1016 mm
Lateral supports	1 right + 1 left
Cable	Three-phase+neutral [5G 2,5]-L=1600 mm
USB port	
Multipoint core probe cod. CHSC3P	
Plug for "vacuum cooking" probe cod. CHSC-SV	
Automatic washing system integrated	
Condensate collection bowl, with drain on door	
Hinge with door locking for openings adjusted at 60°, 90°, 120°, 180°	

Plus

Patented fan guard system Airflowlogic™	
Patented system for direct steam Humilologic™	
Patented system for cooking chamber drying Drylogic™	
Available on request at the order	Voltage (V) : AC 220/230 3 left side opening door
Humidity management software	
Wi-Fi communication system	
Knob for quick selection of the touch screen	
Programmable oven start	
N° 40 recipes stored	
Control panel in 40 languages: Arabic, Armenian, Azerbaijani, Bahasa (Indonesia), Bahasa (Malaysia), Bosnian, Bulgarian, Czech, Chinese, South Korean, Croatian, Danish, Philippine, Finnish, French, Georgian, Japanese, Greek, English, Icelandic, Italian, Kazakh, Lithuanian, Norwegian, Dutch, Persian (Iran), Polish, Portuguese, Romanian, Russian, Serbian, Slovenian, Spanish, Swedish, German, Thai, Turkish, Ukrainian, Hungarian, Vietnamese	
HACCP system	
Adjustable door hinges	